

Design & Development of Lower Extremity Paediatric Prosthesis, a Requirement in Developing Countries

Prasanna K Lenka, M-Tech, Prosthetic & Orthotics Engineer

Dr Amit R Chowdhury, PhD, Biomechanics

Dr Ratnesh Kumar, MBBS, MS (Ortho), DNB (PMR), Director, NIOH

National Institute for the Orthopaedically Handicapped, Kolkata

Abstract

There are more than 10 million physically handicapped people in India. A majority of them belong to poor strata of the society. In the present condition prosthetic fitment centers are not sufficient to deal with such large amputee population. Children are mostly victim of society in low per capita income country in general. Children with congenital amputation, loss of limb with street accidents/trauma, frost bite etc need special attention for the prosthetic fitment. More than 80% of major amputations of the lower extremity are attributed to peripheral vascular disease¹. About 10 percent of congenital anomalies are treated as, or require, amputation². As children are in the growing age, the prosthetic device is required to be changed frequently. This accelerated rehabilitation greatly reduced the overall cost of the patient's care and returned them to full function much faster³. The major constraint in frequent change of prosthetic device in developing country is lack of sufficient number of prosthetic fitment center, skilled prosthetists, paediatric prosthetic kits and low income group of amputee. To face this challenge we have designed a low cost Paediatric prosthetic

Keywords: BK prosthesis, Biomechanic, Adjustable Prosthesis

Introduction

Although many prosthetic principles used in treating adults apply to the treatment of children as well, the child with a lower-limb deficiency presents the prosthetist with a unique range of considerations, both practical and philosophical. Most techniques used with adult amputees must be downsized, sequenced in degree of complexity, modified or completely altered to match the ever-changing needs of children⁴. A sequence of emotions occurs following a traumatic loss of a limb, amputation due to cancer or other disease, or birth of a child with a congenital absence^{5,6}. Each person holds an idealized image of the body, which he uses to measure the percepts and concepts of his or her own body⁷. According to Kolb⁸, an alteration in an individual's body image sets up a series of emotional, perceptual and psychological reactions. Although prosthesis design is a complicated process deals with many discipline including materials science, Prosthetic science, mechanical science, biomechanics etc., the case of children should to be handled very carefully. Child amputees must develop positive self-esteem and body image to achieve self-

acceptance. Body image includes physical, psychological and social aspects and is formed by constantly changing emotions and body perceptions⁹. Disturbances of one's body image occur when changes are not accepted or when previous images do not coincide with reality. If an amputee cannot acknowledge a missing limb, then he or she may never completely accept his or her body or situation.

In the present situation of India, there is no such design to suit children of lower limb amputation. Internationally also percentage of Trans Tibial Amputees (TTA) is more¹⁰. Most of designs including International Committee of the Red Cross (ICRC), Pyramidal, and Artificial Limbs Manufacturing Corporation (ALIMCO) etc are of general type to fit all age group in lower limb. At the growing age in children there is a need of change of prosthesis after 6 months or even earlier to keep the force distribution equal in both limbs and to avoid limb length discrepancy. As shown in figure 2, there was no scope of adjustment in growing children in an ortho-prosthesis. The prosthetic fitment is important in children from psychological point of view and is essential to deliver the prosthesis in a short time for school going children. In India there are insufficient government aided centers for

Address for correspondence: Mr Prasanna Kumar Lenka, NIOH, Bon Hoogly, BT Road, Kolkata 700090. lenka_pk@yahoo.co.uk

prosthetic fitment. Prosthesis is being fitted in centralized locations in the urban areas so traveling cost for people coming for fitment is also a great factor. The cost of prosthesis is also a factor in low income group to do frequent change in children. An indigenously designed prosthetic kit with height adjustment for trans-tibial prosthesis was developed in our institute. The kit consists of an adjustable pylon, coupling device and foot ankle mechanism. The foot ankle mechanism consists of light weight rubber material and a polypropylene keel. The main objective of this development was to design a low cost, light weight and simpler height adjustable pylon with coupling device. The said adjustable pylon has been used for both TTA and congenital limb deficiency for making extension prosthesis in case of growing children. The design is very simple and innovative. It is designed in AutoCAD 2006 and simulated ANSYS®.

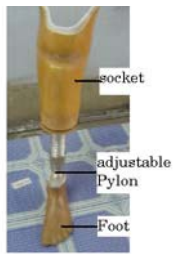

Fig. 1: Parts of Pediatric Prosthesis



Fig. 2: Non adjustable Ortho-prosthesis

Methods

Trans tibial paediatric prosthesis is a scientific mechanical device; the major parts can be categorized as socket, adjustable pylon and foot. The Parts are shown below in figure 1.

Socket is the interface between child’s stump and the prosthetic device and should be changed regularly during their growing age. In most of the conventional design the pylon is an aluminum pipe, stainless steel or titanium pipe and length of the pylon is fixed for a particular child. Feet are available in different sizes and can last for 2 to 3 years for a particular child. Generally for children when a socket is required to be changed, the pylon has to be changed if there is no scope of height adjustment. In case of extension prosthesis also the patient has to bear the cost of new pylon if no scope of height adjustability is incorporated. In figure 2, an ankle foot orthosis (AFO) containing extension with conventional pylon is shown, where there is no scope of height adjustment. In this paper, a height adjustable pylon with locking mechanism at any desirable height is discussed.

Selection and Description of Materials

By proper use of material and structural design, the shank deformability can be altered to mimic natural ankle joint

motions. At the same time, structural integrity should be maintained without permanent deformation and buckling of the prosthesis. Changes in shank flexibility may alter the stress distribution at the prosthetic socket-residual limb interface, which is related to the comfort perceived by the amputees¹¹. In general, two approaches exist for investigating shank deformation and its effect on socket-limb interface stress: experimental measurements and theoretical analyses. Experimental measurements require the use of stress/strain sensors attached to appropriate positions of the shank and the socket inner surface. Theoretical analyses such as finite-element (FE) methods, which have been widely used in lower-limb prosthetics in the past decade, can be useful to study the deformations and stresses. The advantage of the use of FE analysis is that stress, strain, and motion in any parts of the model can be predicted and parametric analyses can be performed easily without the need to fabricate prostheses. In previous FE models, the focus was on investigating the variation of stresses distributed at the limb-socket interface under different socket modifications^{12,13}, material properties of the sockets^{12,14} and liners¹⁵, and frictional properties at the interface¹⁶. We used linear, elastic, isotropic material property throughout the prosthetic model. Different materials were used for different portions of the model especially in the foot. High strength rubber, ordinary rubber, and wood were used for making the foot. Again steel (316-L)/aluminum/nylon was used for making the pylon portion of the model. Initially we designed prototype in aluminum and stress analysis made by ANSYS® under boundary conditions. Basically material selections depend on child weight and different weight range. Our experiment was tried on stainless steel, aluminum and Nylon plastic. Elastic properties (Young’s Modulus and Poissons ratio) of different materials used in the analysis are shown in the following table 1.

	Steel	Aluminum	Rubber	Wood	High Strength Rubber
Young's Modulus (MPa)	0.20530e6	74000	4	12000	6.9
Poisson's Ratio	0.3	0.35	0.45	0.21	0.24

Table-1: Material properties used in Pediatric prosthesis

Technical information

The Components of the Pediatric Prosthesis from top to bottom are

- 1) Socket Adopter
- 2) Socket Aligner Cup
- 3) Upper Shank
- 4) Lower Shank
- 5) Locking Knot
- 6) Foot Aligner Cup
- 7) Socket Fixing Bolt and Washer
- 8) Foot Fixing Bolt and Washer

The CAD drawing of various parts shown in figure-3

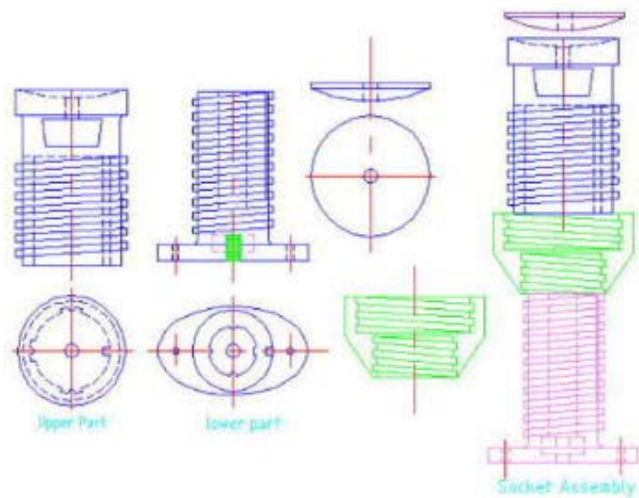

Fig. 3: Auto-Cad Drawing of Parts of adjustable Pylon

Prosthetic fitments were tried on Jaipur foot, Polyurethane (PU) foam foot and child size Solid Ankle Cushioned Heel (SACH) foot. The weight of adjustable pylon for different material is shown below in table 2. Stainless steel pylons were tried on adult patient.

Material	Stainless Steel	Aluminum	Nylon
Weight	1.390 gm	530 gm	400 gm

Table-2: Weight of Pediatric prosthesis in different material

Biomechanical Analysis

To calculate the effectiveness of design both static and dynamic analyses were made. The load limit of this design was tested in Regional Testing Center, Kolkata and observations are given in the results section. A dynamic calculation need completed calculation and scientific instruments¹⁷, a simplified model made from modeling software based on 3D free body diagram

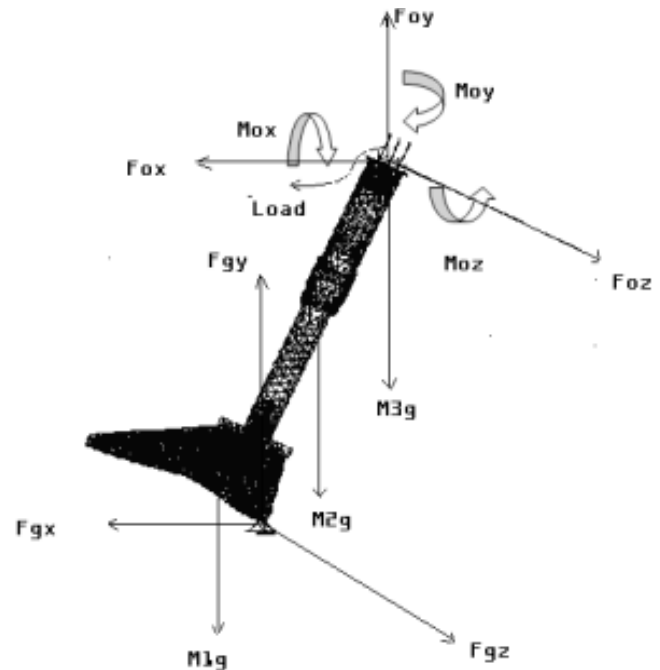

Fig. 4: Free body diagram of Model of Adjustable pylon

explained in figure 4.

F_{ox} , F_{oy} , F_{oz} are force component in X, Y,Z direction applied at the interface between socket adopter and adjustable pylon at the point "O"

M_{ox} , M_{oy} , M_{oz} are Moment component in same way

$$\hat{a} = \ddot{a} \hat{a} / \dot{a}t \text{ and } \tilde{a} = \ddot{a} \hat{a} / \dot{a}t$$

M_i ($i = 1,2,3,\dots$) = Segmental Mass . Shank Upper, Shank Lower and foot plus shoe

L_i ($i=1,2,3,\dots$) = Length of segment from the point "O".

F_{gx} , F_{gy} , F_{gz} are the ground reaction forces measured in force plate on foot.

X_g , y_g , z_g are the distance in x, y, z axes between the point of application of gravity and O

r- Distance form o to CG of whole device

I_o - Moment of Inertia about Z axis

$$M_{oz} - M_1 g l_1 \sin \alpha - M_2 g l_2 \sin \alpha - M_3 g l_3 \sin \alpha + F_{gx} y_g + F_{gy} x_g = I_o \ddot{\alpha} \text{ (1)}$$

$$M_{ox} + F_{gy} z_g + F_{gz} y_g = 0 \text{ (2)}$$

$$M_{oy} + F_{gz} x_g + F_{gx} z_g = 0 \text{ (3)}$$

$$F_{ox} + F_{gx} = (m_1+m_2+m_3) (r \tilde{a} \cos \alpha - r \hat{a}^2 \sin \alpha) \text{ (4)}$$

$$F_{oy} + F_{gy} - (m_1+m_2+m_3) g = (m_1+m_2+m_3) (r \tilde{a} \sin \alpha - r \hat{a}^2 \cos \alpha) \text{ (5)}$$

$$F_{oz} + F_{gz} = 0 \text{ (6)}$$

Based on value of $m_1 = .175$ kg, $m_2 = .197$ kg, $m_3 = .875$ kg and lengths of different component for a particular prototype made up of aluminum the r and I_o are calculated.

Total Strength of coupling device and kinetic energy required to propel or walk for a child is also evaluated.

From the dynamic equations of both rotational and translational movement, the total force falling on interface of socket and adjustable pylon was simulated.

Statistics

For clinical trial participant mainly children from both sex and different age group were considered to check and bench mark the viability of the new design. Among them some of them were first time users.

Here only TTA statistics are shown; however we have fitted three extension prostheses and two trans-femoral (TF) without knee joint for children of age 5 to 12 years.

From the distribution graph shown in figure 5, it is seen that most of children fall under the age group of 9-12 and corresponding body weight of 20 to 35 kg.

Results

As per conditions of Assistance to Disabled Persons (ADIP) scheme by the government of India, a child can get a new prosthesis after one year free of cost if he/she belongs to below the poverty line income group. In the new design, only socket change and little adjustment in cosmetic can increase the life span of the prosthesis further without the need for discarding the prosthesis fully. The cost of socket and cosmetic cover can be treated as repair cost which under the scheme can indirectly help a lot of poor patients.

Out of 28 children, we have changed socket in following manner:

1. Two times in six month interval- 15
2. One time after three months interval-5
3. No change-5
4. Not Reported for follow up-3

The concept in pediatric prosthesis was tried on bilateral amputee also. As we know stability and confidence is most important in case of bilateral amputation, so height was adjusted from minimum to actual in a phased manner. From stability point of view lower height of CG means more stability. The cost of adjustable pylon in Nylon and Polypropylene is only Rs 200/- (Two hundred only), where as the conventional pylon with coupling device in India is Rs 800/- (Eight hundred only).

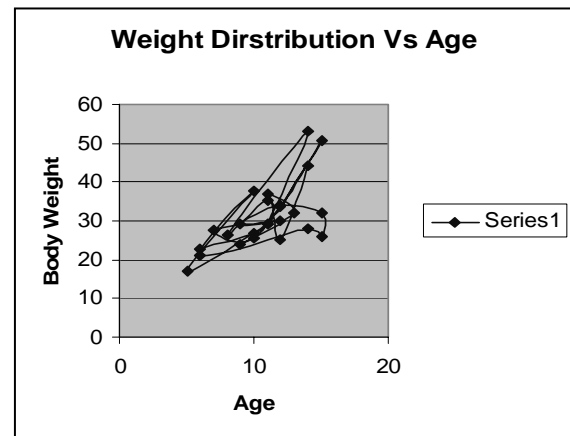

Figure-5: Age and Weight distribution of Subjects

Discussion

The commonly available endoskeletal prosthetic designs in India are from the following institutions

National Institute for Rehabilitation Training and Research (NIRTAR) Design

ICRC technology

Christian Medical College (CMC) Vellore

ALIMCO design (Pyramidal type)

Mobility India

Each of above design has its own advantages and disadvantages as it needs high skilled professional to fabricate align and fit. The electric and metal cutting tools are needed. There is no provision of height adjustment. It is also not suitable for children as far as the size and weight are concerned. Moreover, the long-term studies are not available on their usage. The proposed design appears to have advantage of simplicity, height adjustment and better load distribution. The New design is especially suitable for children and economically viable in countries with people having low socio-economic status.

In summary, the advantages of the new prosthesis are height adjustability, ease of fabrication, being light in weight, re-adjustability, reusability and low cost.

References

1. Lee D. Faucher, MD, Donald G. Shurr, CPO, PT. Ambulation on Postoperative Day 1 after Bilateral Transtibial Amputations A Case Report and Literature Review, Journal of Prosthetics & Orthotics 2005; 17: 47-49.
2. Challenor YB. Limb deficiencies in children. In: Molnary GE, ed. Pediatric rehabilitation. Baltimore, MD: Williams & Wilkins, 1985: 177-197.

3. Feinglass J, brown JL, Losasso A, et al. Rate of Lower extremity amputation and arterial reconstructions in united states 1979 to 1996, Am J Public health 1999;89: 1222-1227.
4. Donald R. Cummings, Susan L. Kapp, CP, Lower-Limb Pediatric Prosthetics: General Considerations and philosophy JPO 1992; 4 (4): 196-206.
5. Drotar D, Baskiewicz A, Irvin N, Kennell J, Klaus M. The adaptation of parents to the birth of an infant with a congenital malformation: a hypothetical model. Pediatrics 1975; 56: 710-7.
6. Turgay A, Sonuvar B. Emotional aspects of arm or leg amputation in children. Canadian Journal of Psychiatry 1983; 28:294-7.
7. Kolb LC. Disturbances in body image. In: Arieti S, ed., American Handbook of Psychiatry. New York: Basic Books, 1959; 1: 749-69.
8. Kolb LC. Disturbances in body image. In: Arieti S, Reiser MF, eds. American Handbook of Psychiatry. New York: Basic Books 1975; 4: 810-37
9. Novotny MP. Body image changes in amputee children: how nursing theory can make the difference. Journal of the Association of Pediatric Oncology Nurses 1986; 3: 8-13.
10. Bodily KC, Burgess LM, Contra lateral Limb and patient survival after leg amputation, Am J Surgery 1983; 146: 280-2.
11. Winson C. C. Lee, BSc; Ming Zhang, PhD; David A. Boone, CP, BS, MPH; Bill Contoyannis, MEng Sc, Finite-element analysis to determine effect of monolimb flexibility on structural strength and interaction between residual limb and prosthetic socket. JRRD 2004; 41: (6A): 775-86
12. Silver-Thorn MB, Childress DS. Parametric analysis using the finite element method to investigate prosthetic interface stresses for persons with trans-tibial amputation. J Rehabil Res Dev. 1996; 33: 227-38.
13. Reynolds DP, Lord M. Interface load analysis for computer-aided design of below- knee prosthetic sockets. Med Biol Eng Comput. 1992; 30: 419-26.
14. Quesada P, Skinner HB. Analysis of a below-knee patellar tendon-bearing prosthesis: a finite element study. J Rehabil Res Dev. 1991; 28: 1-12.
15. Simpson G, Fisher C, Wright DK. modeling the interactions between a prosthetic socket, polyurethane liners and the residual limb in transtibial amputees using non-linear finite element analysis. Biomed Sci Instrum. 2001; 37: 343-7.
16. Jia X, Zhang M, Lee WCC. Load transfer mechanics between transtibial prosthetic socket and residual limb- a dynamic effects Journal of Biomechanics.2004; 37: 1371-7.

**Mid Term CME of IAPMR
Imphal, Manipur, India
August 30-31, 2008**

Organizers:

Dr. Kunjabasi Wangjam
Organizing Chairman
M.S.(Ortho), Diplomate N.B (PM & R)
Professor & HOD
Physical Medicine Rehabilitation Department
Regional Institute of Medical Sciences
Imphal-795004

Tel: 0385 2414493(O); Fax: 0385 2414625
email: w_kunjabasi@dataone.in

Dr. N Romi Singh
Organizing Secretary
Diplomate N.B.(PM & R), MNAMS
Associate Professor
Physical Medicine Rehabilitation Department
Regional Institute of Medical Sciences
Imphal-795004

Tel: 0385 2414493(O); Fax: 0385 2414625
email: dr.romi.singh@gmail.com

For further details, please visit: <http://iapmr-mid-term-cme.9f.com/index.html>
